

Temperature Sensors

The Watlow
Educational Series
Book Four



Temperature Sensors

Contents

Objectives	3
Introduction	3
Thermal System Review	3
Thermocouple	4
Thermocouple Function	4
Polarity	7
Thermocouple Standards	8
Thermocouple Selection	9
Thermocouple Identification	12
Thermocouple Assemblies	13
Insulated Wire Thermocouples	13
Ceramic-Beaded Thermocouples	14
Metal-Sheathed Thermocouples	14
Junction Types	15
Thermocouple Review Questions	16
Resistance Temperature Detector (RTD)	17
RTD Standards	18
RTD Advantages/Disadvantages	19
RTD Lead Wire Effects	21
RTD Identification	22
RTD Assemblies	23
RTD Review Questions	23
Thermistor	24
Thermistor Standards	25
Thermistor Lead Wire Effects	26
Thermistor Assemblies	26
Infrared Sensor	26
Infrared Sensor Function	26
Emissivity Effects	27
Sensor-to-Target Distance	28
Operating Environment	29
Ambient Temperature Fluctuations	30
Advantages/Disadvantages of the Four Sensor Types	30
Booklet Review Questions	31
Answers to Exercises and Review Questions	33

Objectives

The objectives of this booklet are to enable you to:

- List the 4 types of temperature sensors and explain how each works.
- List at least 3 advantages and disadvantages of each sensor type.
- Explain the effects of reversed polarity on thermocouple connections.
- Describe the reasons why different thermocouple types are used.
- Apply initial calibration tolerances and explain why sensor tolerances are only valid for the first (initial) use.
- Use color coding, magnetism, resistivity characteristics and other information to identify thermocouple types.
- Describe the 3 types of thermocouple constructions and the 3 junction types used in metal-sheathed thermocouples.
- Explain the JIS and DIN RTD resistance standards.
- Explain RTD lead wire effects and how this problem is solved.
- Describe the 2 general types of industrial RTD constructions.
- Describe how to identify 3 and 4-wire RTDs.
- Explain what problem the lack of thermistor standards can cause.
- Explain why objects should have high emissivities when using IR sensors.
- Explain why an IR sensor's "field of view" and "spot size" are important.
- Describe sensor-to-target distance, sensor orientation, operating environment and ambient temperature effects on IR sensor application.

Introduction

The importance of temperature sensors in many thermal systems is virtually ignored. Within that ignorance lies tremendous opportunities for you to make yourself valuable to your customers! This study guide begins opening up those opportunities for you. We explore the four basic types of sensors Watlow Gordon and Watlow Infrared offer. We discover how they work and learn about some of each sensor's unique features and advantages (as well as disadvantages).

Thermal System Review

The temperature sensor is the "nervous system" of the controller. Just as you rely on your sense of touch, so a temperature controller relies completely on the sensor. The controller uses the sensor signal to decide whether to turn the heater on or off to maintain the desired set point temperature (Figure 1).

Temperature Sensors

Thermal System Review
(con't)

Figure 1
A Simple Thermal System

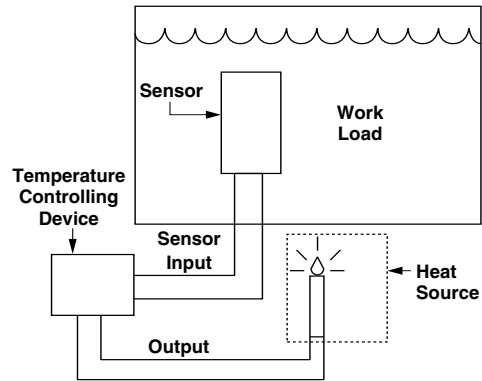

What happens, then, if the sensor signal is inaccurate? The controller has *no way of knowing* that a sensor's signal is inaccurate. Therefore, it will control the thermal system based on that "bad" signal. To prevent those "bad" signals, let's jump in and explore the world of temperature sensors. The four categories of temperature sensors covered in this booklet are: thermocouples, resistance temperature devices (RTD), thermistors and infrared sensors.

Thermocouple

Thermocouples are by far the most widely used type of sensor in industry. They are very rugged and can be used from sub-zero temperatures to temperatures well over 4000°F (2000°C). What is a thermocouple and how does it work? How many forms does it take and what are the different types used? All good questions deserving of good answers!

Thermocouple Function

A thermocouple is formed by joining two *different* metal alloy wires (A and B) at a point called a junction (Figure 2). This junction is called the measuring or "hot" junction. The thermocouple lead ends are usually attached to a temperature indicator or controller. This connection point is called the reference or "cold" junction.

Figure 2
A Thermocouple Circuit

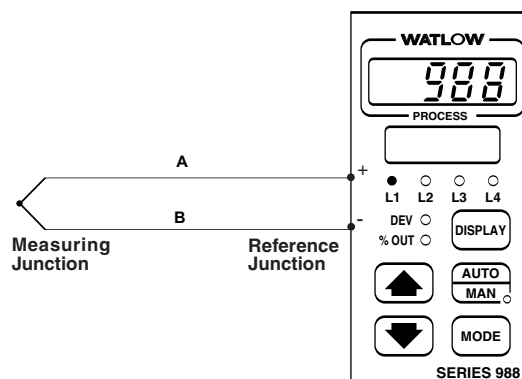

**Thermocouple Function
(con't)**

When the measuring junction is heated, a small DC voltage is generated in the thermocouple wires. The controller measures this millivolt signal and converts it into a temperature reading. The voltage generated in the thermocouple is so small that it is measured in millivolts. One millivolt is equal to 0.001 volt.

It looks like thermal energy is somehow inducing the voltage (electrical energy) into the thermocouple, doesn't it? Yes! Simply put, a thermocouple *converts thermal energy into electrical energy*. The temperature controller uses this electric energy (millivolt signal) to measure thermocouple temperature.

Figure 3 shows some millivolt versus temperature values for a "Type J" thermocouple. Notice how the millivolt output increases as temperature increases. If the temperature were to decrease and go below 0°C (32°F), the millivolt output would become negative.

Figure 3
Type J Voltage (EMF) Output Vs Temperature

°C	0	1	2	3	4	5	6	7	8	9	10	°C
0.0	0.000	-0.050	-0.101	-0.151	-0.201	-0.251	-0.301	-0.351	-0.401	-0.451	-0.501	0.0
0.0	0.000	0.050	0.101	0.151	0.202	0.253	0.303	0.354	0.405	0.456	0.507	0.0
10.0	0.507	0.558	0.609	0.660	0.711	0.762	0.814	0.865	0.916	0.968	1.019	10.0
20.0	1.019	1.071	1.122	1.174	1.226	1.277	1.329	1.381	1.433	1.485	1.537	20.0
30.0	1.537	1.589	1.641	1.693	1.745	1.797	1.849	1.902	1.954	2.006	2.059	30.0
40.0	2.059	2.111	2.164	2.216	2.269	2.322	2.374	2.427	2.480	2.532	2.585	40.0
50.0	2.585	2.638	2.691	2.744	2.797	2.850	2.903	2.956	3.009	3.062	3.116	50.0
60.0	3.116	3.169	3.222	3.275	3.329	3.382	3.436	3.489	3.543	3.596	3.650	60.0
70.0	3.650	3.703	3.757	3.810	3.864	3.918	3.971	4.025	4.079	4.133	4.187	70.0
80.0	4.187	4.240	4.294	4.348	4.402	4.456	4.510	4.564	4.618	4.672	4.726	80.0
90.0	4.726	4.781	4.835	4.889	4.943	4.997	5.052	5.106	5.160	5.215	5.269	90.0
100.0	5.269	5.323	5.378	5.432	5.487	5.541	5.595	5.650	5.705	5.759	5.814	100.0

Thermoelectric voltage as a function of temperature (°C), reference junctions at 0°C. Voltage values in millivolts

Exercise One

Please turn to the Thermocouple Temperature Vs EMF Tables in the Application Guide of the Watlow Gordon catalog. Using the Type J table, fill in the millivolt values for a Type J thermocouple at the temperatures below. Answers - page 33.

0°C (32°F) _____ 20°C (68°F) _____
 200°C (392°F) _____ 560°C (1040°F) _____

From Exercise One, we anticipate that a Type J thermocouple will produce 1.019 millivolts (mV) at 20°C (68°F). To prove this, let's connect a Type J thermocouple to a voltmeter and measure the millivolt output (Figure 4). Of course, we make 100% sure that the entire thermocouple is at 20°C (68°F). What will the voltmeter read?

Temperature Sensors

Thermocouple Function (con't)

A temperature difference between the "hot" and "cold" junctions causes the voltage "build up" in a thermocouple. This voltage value is then used to measure temperature.

Figure 4

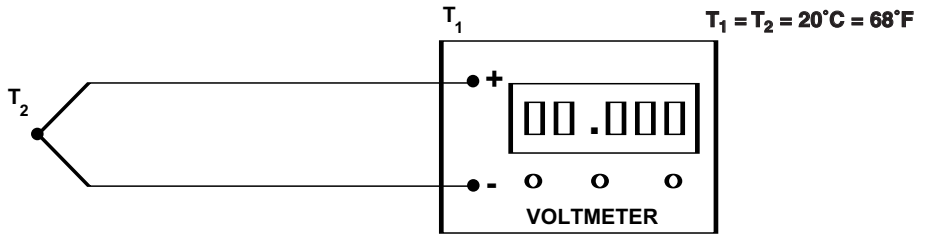

The voltmeter display shows zero volts! What's wrong? The display should read 1.019 according to the table we used. What happened? If there is no problem with the test, *why* do we measure zero volts? AAHHH...our journey of thermocouple discovery takes a twist!

You see, a thermocouple only generates a millivoltage signal when there is a **temperature difference** between the measuring and reference junctions. In our test, the entire thermocouple is at 20°C (68°F). There is no temperature difference. THAT is why we measured zero volts on the voltmeter. No temperature difference, no millivolt signal!

Then why does the millivolt table show 1.019 mV measured at 20°C (68°F)? Read the note at the bottom of the millivolt table. The note states "..., reference junction at 0°C." Ah ha! When they make these tables, they hold the reference junction at the freezing point of water (0°C or 32°F). Then they vary the measuring junction temperature and measure the corresponding millivolt values. When the measuring junction was at 20°C (68°F), they measured 1.019 mV.

What, then, is the millivolt output of a thermocouple at 32°F (0°C)? Check the table back on page 5. The output at 32°F is zero volts - just as it should be! Both junctions are at the same temperature (32°F). No temperature difference, no millivolt signal.

Let's connect the Type J thermocouple in Figure 4 up to a temperature controller (Figure 5). When we do this the temperature controller reads 20°C (68°F). Why does a temperature controller read the correct temperature if there is no millivolt signal output? Good question.

Figure 5

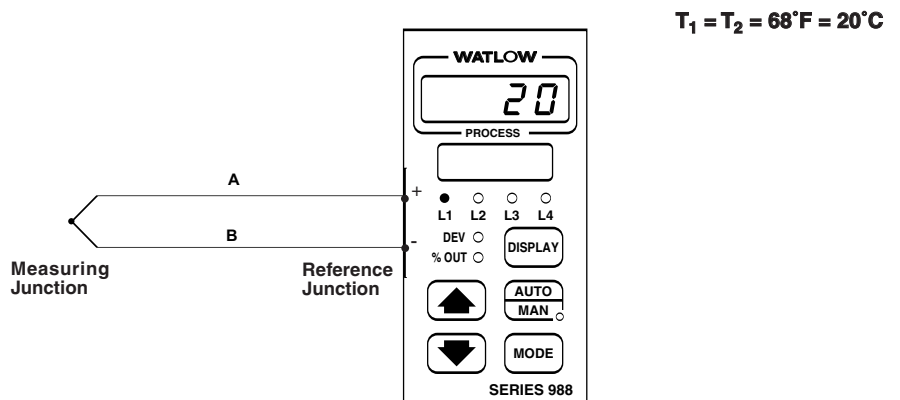

**Thermocouple Function
(con't)**

The controller automatically corrects or “compensates” for the reference junction temperature. It does this by using a small temperature sensor to measure the reference junction temperature. Then the controller electronically “adds in” a reference junction temperature adjustment. That is why it displays the correct temperature!

For example, a controller measures a reference junction temperature of 20°C (68°F). If a Type J thermocouple is used, the controller automatically *adds* 1.019 millivolts to any signal it receives from the thermocouple. If the measuring junction is also at 68°F, the controller receives 0 mV. The total then is 1.019 millivolts. The controller will then display 20°C (or 68°F). Simple, isn't it?

Polarity

A thermocouple, as we mentioned earlier, produces a DC voltage. Thus, one of the thermocouple's wires (or “legs”) is positively charged and one of the legs is negatively charged. Why is this important? When connecting the thermocouple to an instrument like a controller, the **polarity** of the legs and controller terminals must match. In other words, the positive leg must be connected to the positive terminal and negative leg to the negative terminal. What happens if the thermocouple legs are accidentally reversed?

The controller is tricked! The controller now receives a millivolt signal which *decreases* as sensor temperature increases. As a result, it will keep the heater on all the time. The hotter the sensor gets, the *colder the controller thinks* it is getting.

Figure 6
Reverse Polarity Effects for a Type J Thermocouple

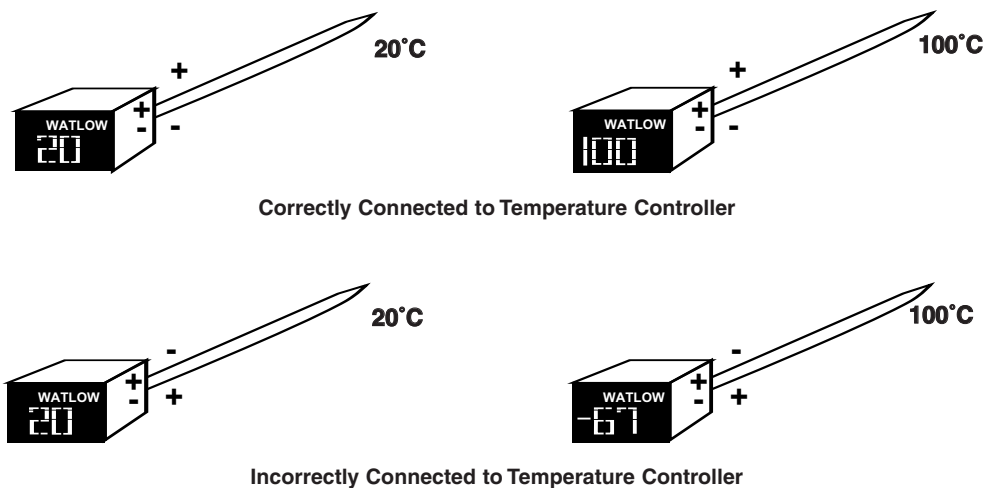

When a thermocouple is connected with reversed polarity, it tricks the temperature controller into thinking that the temperature is decreasing, when it is really increasing.

Obviously, the controller will keep the heater on until the thermal system overheats. This will damage or destroy the thermal system. It is easy to see a reversed polarity connection. If you know a sensor's temperature is increasing, but the control shows the temperature decreasing, then you know the reason is a reversed polarity.

Temperature Sensors

Thermocouple Standards

As stated earlier, a thermocouple is made up of two *different* metal alloy wires. There are many types of thermocouples from which to choose. To make life easy, though, certain combinations of alloys have become standards. These standards are known as “types.” For example Type J, Type K, etc. Figure 7 lists types, alloys and temperature ranges for the most common thermocouples.

Figure 7
Thermocouple Types

Thermocouple Standard Type	Metal Content in Positive Leg	Metal Content in Negative Leg	Temperature Range
B	70.4% Platinum (Pt), 29.6% Rhodium (Rh)	93.9% Pt, 6.1% Rh	1600 - 3100°F (870 - 1700°C)
E	90% Nickel, (Ni), 10% Chromium (Cr)	55% Copper (Cu), 45% Ni	32 - 1650°F (0 - 900°C)
J	99.5% Iron (Fe)	55% Cu, 45% Ni	32 - 1380°F (0 - 750°C)
K	90% Ni, 10% Cr	95% Ni, 5% Various Elements	32 - 1380°F (0 - 1250°C)
N	84.4% Ni, 14.2% Cr 1.4% Silicon	95.5% Ni, 4.4% Si	32 - 2280°F (0 - 1250°C)
R	87% Pt, 13% Rh	100% Pt	32 - 2640°F (0 - 1450°C)
S	90% Pt, 10% Rh	100% Pt	32 - 2640°F (0 - 1450°C)
T	100% Copper (Cu)	55% Cu, 45% Ni	-330 - 660°F (-200 - 350°C)
C*	95% Tungsten (W), 5% Rhenium (Re)	74% Tungsten (W), 26% Rhenium (Re)	32 - 4200°F (0 - 2315°C)
D*	97% W, 3% Re	75% W, 25% Re	32 - 4200°F (0 - 2315°C)
G*	100% W	74% W, 26% Re	32 - 4200°F (0 - 2315°C)

* Not Official ANSI (American National Standards Institute) designations.

Using a thermocouple type other than that which the controller input accepts will cause measuring error. The millivolt values for the various thermocouples are all different for a given temperature.

Each thermocouple type generates a *different* millivoltage signal at any given temperature. Why is this important? Let’s do an exercise to find out.

Exercise Two

Please turn to the “Thermocouple Temperature Vs. EMF Tables” located in the Application Guide of the Watlow Gordon catalog. Compare the millivolt signal for thermocouple Types J, K and T at 160°C (320°F). Remember, the reference junction is at 0°C. Write in the values below. Answers on page 33.

Type J: _____ Type K: _____ Type T: _____

Notice that the values are very different from each other? What does this tell you? Can we use a Type K or T thermocouple for a control which is set up to use Type J? No! If we switch thermocouples, we trick the control! Now the controller will regulate the work load temperature based on the **wrong** millivolt signal. This will cause lots of problems. That is why thermocouple types are NOT interchangeable. Always ensure that the correct thermocouple is used.

Thermocouple Selection

You are probably sitting there wondering why there are so many thermocouple types (instead of just one or two). Each thermocouple type has advantages and disadvantages over other thermocouple types. In this section, we examine some general points of comparison to give you a “flavor” for thermocouple selection. Refer to the Watlow Gordon catalog for more detailed information.

Cost

If we look at the chart in Figure 7, we can divide the thermocouples up by their relative costs. The lower price thermocouples are those made of low cost metals. These thermocouples are known as “base metal” (or common metal) thermocouples. The **base metal** thermocouples are Types E, J, K, N, and T.

Customers occasionally want to use Type K and N thermocouples above their max. temperature rating to avoid having to buy expensive noble metal thermocouples.

The most popular base metal thermocouples are Type K, followed closely by Type J. These thermocouples are inexpensive, accurate and easily used in the majority of industrial applications. Most instruments and controllers use one or both of these thermocouple types.

The more expensive thermocouples are known as noble metal (or rare metal) thermocouples. The **noble metal** thermocouples are Types B, R and S. These platinum-rhodium thermocouples are many times more expensive than base metal thermocouples. Why? Platinum and rhodium are rare, expensive metals.

There are advantages to paying the higher prices for noble metal thermocouples. Do you see any advantages in Figure 8? Sure! Noble metal thermocouples can be used at higher temperatures and have a much higher accuracy.

Temperature Range

Obviously, the operating temperature of a thermal system will dictate what thermocouple we can choose. If the operating temperature is 700°F (370°C), for example, what thermocouples can we use? Looking at Figure 7 or 8, we can use any thermocouple, except Type T. Most likely, we will use Type J or Type K.

Accuracy

Accuracy is defined as the amount of error which exists in a temperature measurement. It indicates how close measured values are to the true temperature value. This is also called “tolerance” or “error.” A chart called “Initial Calibration Tolerances” in Figure 8 tells us what accuracy or “tolerance” we can expect from a given thermocouple.

The table in Figure 8 is very easy to use. To calculate the initial accuracy of a thermocouple, you simply determine the greater of the two tolerance values given. Let’s work through an example.

Example: A Type K thermocouple is heated up to 200°C. What is the standard tolerance at this temperature? From Figure 8, it is either $\pm 2.2^\circ\text{C}$ or $\pm 0.75\%$, whichever is greater. How do we know which is greater? We have to convert the $\pm 0.75\%$ tolerance into a $\pm ^\circ\text{C}$ value and compare to $\pm 2.2^\circ\text{C}$.

To do this, multiply 200°C by ± 0.0075 to get $\pm 1.5^\circ\text{C}$. At 200°C , the accuracy is $\pm 2.2^\circ\text{C}$. We choose $\pm 2.2^\circ\text{C}$, because it is *greater* than the $\pm 1.5^\circ\text{C}$ we calculated using the percentage value. If the value calculated by using the percentage tolerance was higher than $\pm 2.2^\circ\text{C}$, we would have chosen it instead.

Temperature Sensors

Thermocouple Selection (con't)

Figure 8
Initial Calibration Tolerances for Thermocouples

Thermocouple Type	Maximum Temperature	Tolerances	
		Standard	Special
E	1650°F (900°C)	± 1.7°C (± 3.06°F) or ± 0.5% (whichever is greater)	± 1.0°C (± 1.8°F) or ± 0.4% (whichever is greater)
J	1380°F (750°C)	± 2.2°C (± 3.96°F) or ± 0.75%	± 1.1KC (± 1.98°F) or ± 0.4%
K, N	2280°F (1250°C)	± 2.2°C (± 3.96°F) or ± 0.75%	± 1.1KC (± 1.98°F) or ± 0.4%
T	660°F (350°C)	± 1.0°C (± 1.8°F) or ± 0.75%	± 0.5°C (± 0.9°F) or ± 0.4%
B	3100°F (1700°C)	± 0.5%	—
R,S	2640°F (1450°C)	± 1.5°C (± 2.7°F) or ± 0.25%	± 0.6°C (± 1.08°F) or ± 0.1%
C*, D*, G*	4200°F (2315°C)	± 4.5°C (± 8.1°F) or ± 1.0%	—

* Not Official ANSI designations.

The accuracy of the entire control system is found by adding the sensor accuracy to the controller and digital display accuracies.

What is the difference between standard and special tolerance thermocouples? After studying Figure 8 for a moment, you soon discover that special tolerances are much higher than standard tolerances. Special tolerances are usually a little more expensive than standard tolerances. The tolerance or accuracy, however, is almost twice as good! Special tolerances are calculated exactly the same way that standard tolerances are.

Exercise Three

A customer requires an accuracy of ± 2°C at an operating temperature of 500°C. The customer does not want to buy a “noble metal” thermocouple. Which thermocouple(s) can you recommend for this customer? Special tolerances can be used if required. Answers are on page 33.

Instead of calculating these tolerances, we can make life easy and just use a tolerance table in the Watlow Gordon Application Guide (Figure 9). A portion is reproduced below. This table shows tolerances in degrees Fahrenheit.

Figure 9
Initial Calibration Tolerances for Thermocouples and RTDs

Temperature °F (°C)		RTD DIN or JIS A B		Initial Calibration Tolerances (±°F)										
				Thermocouple										
				Type B STD	Type E STD SPL		Type J STD SPL		Type K, N STD SPL		Type R, S STD SPL		Type T STD SPL	
100	38	0.41	0.88		3.06	1.80	3.96	1.98	3.96	1.98	2.70	1.08	1.80	0.90
150	66	0.51	1.13		3.06	1.80	3.96	1.98	3.96	1.98	2.70	1.08	1.80	0.90
200	93	0.61	1.38		3.06	1.80	3.96	1.98	3.96	1.98	2.70	1.08	1.80	0.90
250	121	0.71	1.63		3.06	1.80	3.96	1.98	3.96	1.98	2.70	1.08	1.80	0.90
300	149	0.81	1.88		3.06	1.80	3.96	1.98	3.96	1.98	2.70	1.08	2.01	1.07
350	177	0.91	2.13		3.06	1.80	3.96	1.98	3.96	1.98	2.70	1.08	2.39	1.27
400	204	1.01	2.38		3.06	1.80	3.96	1.98	3.96	1.98	2.70	1.08	2.76	1.47
450	232	1.11	2.63		3.06	1.80	3.96	1.98	3.96	1.98	2.70	1.08	3.14	1.67
500	260	1.21	2.88		3.06	1.87	3.96	1.98	3.96	1.98	2.70	1.08	3.51	1.87
550	288	1.31	3.13		3.06	2.07	3.96	2.07	3.96	2.07	2.70	1.08	3.89	2.07

**Thermocouple Selection
(con't)**

Life

“How long will this thermocouple last?” This is one of the most frequently asked questions about thermocouples. How should you answer? Try, “It depends.” Diplomatic, heh? Seriously, the fact is that it DOES depend. Life depends on many factors. Among them: operating temperature, thermocouple wire size, thermocouple protection, operating environment, accuracy required, etc. Instead of examining each point in detail, let’s focus on “life” and how it relates to thermocouple accuracy.

Normally, thermocouples don’t “fail” like electric heaters. When an electric heater “fails”, it burns out - no more heat. A thermocouple, on the other hand, gets more and more inaccurate as time goes on. At some point, the accuracy is so “bad” that the thermocouple is said to have “failed.” Here’s how it works.

When thermocouple wires are heated and cooled, physical and chemical changes take place. Physically, the metallurgical structure of the thermocouple metal changes. Chemically, the thermocouple wires react with oxygen or other substances. These chemical reactions *change the chemical composition* of the thermocouple wire. The chemical reactions are accelerated at higher temperatures.

As these chemical (and physical) changes take place over time, a thermocouple’s millivolt signal “drifts” (Figure 10). The result is that the thermocouple will no longer measure temperature within its stated accuracy band. “Drifting” may start within a few minutes or may take many months - it all depends on how a thermocouple is used. This is also the reason why tolerances are called **initial** calibration tolerances. The tolerances are only valid for the very first use. After the first use, **there is no guarantee that the tolerance will hold.**

Oxidation and chemical attack of thermocouple wires changes their chemical composition. This, in turn, will change their millivolt output and cause measuring errors.

Thermocouple “drift” may be downward (as shown in Figure 10) or upward. It depends on the thermocouple type and the cause of the drift.

Figure 10
Thermocouple EMF Vs. Time

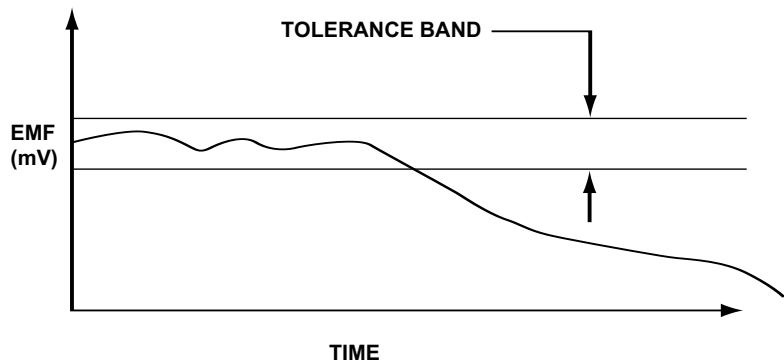

The life of a thermocouple, then, is more of an accuracy problem. The more “drift” a customer is willing to tolerate, the longer the “life” he/she can get out of a given thermocouple. As a result, “life” means something different to everyone. Your job is to determine what it means to the customer at hand. Then based on those answers, start working on a thermocouple solution.

Users often prolong a thermocouple’s life by “recalibrating” at periodic intervals. **Calibrating** a thermocouple simply means measuring the accuracy of the millivolt signal and adjusting the controller to compensate for any errors. Calibrating is often done on a periodic basis, say every 3 or 6 months.

Temperature Sensors

Thermocouple Identification

Occasionally, a customer will ask you to identify what type of thermocouple he or she has. You're in luck! There are many ways to identify thermocouple types. We start out with the easiest - color coding.

Thermocouple wires are often manufactured with an insulation covering over the bare wires. The insulation electrically isolates the wires. Fortunately, each thermocouple type uses a special color coded insulation. The chart in Figure 11 shows the color code combinations used by several different nations.

Figure 11
Thermocouple Wire Insulation Color Codes

Note:

Standard ANSI color coding (United States) is used on all insulated thermocouple wire and extension wire when type of insulation permits. In color coding, the right is reserved to include a tracer to identify the ANSI type. Thermocouple grade wire normally has a brown overall jacket. For Types B, R and S the color codes relate to the compensating cable normally used.

T/C Type	ANSI* MC96.1 T/C	ANSI* MC96.1 Extension	UK BS 1843	Germany DIN 43714	Japan JIS C1610-1981	France NF C42-323
B (overall)	—	Grey	—	Grey	Grey	—
BP	—	+Grey	—	+Red	+Red	—
BN	—	-Red	—	-Grey	-White	—
E (overall)	Brown	Purple	Brown	Black	Purple	—
EP	+Purple	+Purple	+Brown	+Red	+Red	—
EN	-Red	-Red	-Blue	-Black	-White	—
J (overall)	Brown	Black	Black	Blue	Yellow	Black
JP	+White	+White	+Yellow	+Red	+Red	+Yellow
JN	-Red	-Red	-Blue	-Blue	-White	-Black
K (overall)	Brown	Yellow	Red	Green	Blue	Yellow
KP	+Yellow	+Yellow	+Brown	+Red	+Red	+Yellow
KN	-Red	-Red	-Blue	-Green	-White	-Purple
N (overall)	Brown	Orange	—	—	—	—
NP	+Orange	+Orange	—	—	—	—
NN	-Red	-Red	—	—	—	—
R (overall)	—	Green	Green	—	Black	—
RP	—	+Black	+White	—	+Red	—
RN	—	-Red	-Blue	—	-White	—
S (overall)	—	Green	Green	White	Black	Green
SP	—	+Black	+White	+Red	+Red	+Yellow
SN	—	-Red	-Blue	-White	-White	-Green
T (overall)	Brown	Blue	Blue	Brown	Brown	Blue
TP	+Blue	+Blue	+White	+Red	+Red	+Yellow
TN	-Red	-Red	-Blue	-Brown	-White	-Blue

* American National Standards Institute — U.S. Standards.

Example: A customer calls and says that he requires a thermocouple replacement for a new machine bought from Germany. The wire colors are blue and red. Which thermocouple is it most likely to be? Using Figure 11, it is most likely a Type J thermocouple, because it is a German machine and the color codes used are most likely German standards.

How can we be sure it is a Type J? It could be a Type T thermocouple per U.S. standards. What else can we try? Some other options are: checking magnetism, checking which color wire goes to + and - control terminals, checking the controller manual for information, and measuring wire resistivity.

So in the above example, we check magnetism. Per Figure 12, if one of the wires is magnetic, it is a Type J thermocouple. If no legs are magnetic, it is a Type T thermocouple. As an option we can also measure wire resistivity and compare results. We can also check which color wire is connected to the + terminal on the controller.

Thermocouple Selection
(con't)

Figure 12
Comparison of Identification Criteria for Thermocouples

Comparison Criteria	Type B	Type E	Type J	Type K	Type N	Type R, S	Type T
Insulation* Color (U.S.)	+Gray -Red	+Purple -Red	+White -Red	+Yellow -Red	+Orange -Red	+Black -Red	+Blue -Red
Magnetism	—	—	Positive leg is magnetic	Negative leg is magnetic	—	—	—**
Wire Resistivity*** (Same Size Wires)	—	Negative leg is 0.7 times the positive leg	Negative leg is 5.5 times the positive leg	Positive leg is 2.5 times the negative leg	Positive leg is 2.6 times the negative leg	Positive leg is 2 times the negative leg	Negative leg is 30 times the positive leg

* Use color code chart in Figure 11 to identify color codes for other countries.

** The positive leg has a distinctly copper color, the negative leg has a silver color.

*** Assumes no contamination or oxidation of the thermocouple wires measured.

Thermocouple Assemblies

Now that you know how a thermocouple works, lets take a brief look at the thermocouple constructions (or assemblies) you can expect to see out in the real world. There are 3 general types of thermocouple constructions: insulated wire, ceramic-beaded and metal-sheathed thermocouples.

Insulated Wire Thermocouples

As the name implies, bare thermocouple wires are wrapped or covered with insulation. The insulation is typically a fibrous, woven material made of fiber-glass, mica or ceramic fiber. Other insulation types are plastics (like Teflon®) and polyimides (like Kapton®). See Figure 13 for examples.

Figure 13
Examples of Fibrous and Plastic Insulated Thermocouple Wire

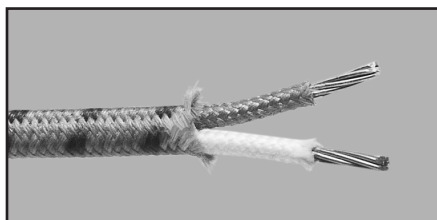

Fiberglass Insulated Wire
Watlow Gordon Series 302

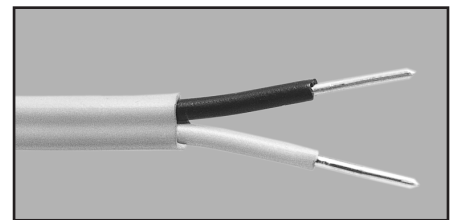

PVC Insulated Wire
Watlow Gordon Series 502

The insulation serves primarily to electrically isolate (insulate) the thermocouple wires. It also protects the wires from some contamination and allows easier wire installation. The insulation material is chosen based on the operating temperature and environmental conditions (like exposure to moisture, chemicals, etc.). Thermocouples are made by stripping the insulation off the wire and welding the wires together to make a junction.

Teflon® and Kapton® are registered trademarks of E.I. Du Pont Co.

Temperature Sensors

Ceramic - Beaded Thermocouples

These thermocouples are fairly large diameter wires junctioned and insulated with ceramic insulators or “beads.” These beads provide electrical insulation between the wires and between the wires and any protective metal tube used.

Figure 14
A Ceramic Beaded Thermocouple



Thermocouple Element, Twisted and Welded



Thermocouple Element, Butt Welded

These thermocouples (like those in Figure 14) are placed inside of metal or ceramic protection tubes to protect the thermocouple from contamination. Ceramic beaded thermocouples are principally used in ovens and furnaces.

Metal - Sheathed Thermocouples

A large portion of the thermocouples sold are metal-sheathed thermocouples. As the name implies, the thermocouple junction and wires are assembled in small diameter metal tubes. The thermocouple wires are insulated using either fiberglass or MgO insulation (see Figure 15).

Figure 15



a. A metal-sheathed “tube and wire” thermocouple assembly using fiberglass insulation.



b. A metal-sheathed thermocouple using compacted MgO insulation. Notice the transition fitting. It is there that the flexible lead wires are connected to thermocouple wires buried inside of the compacted MgO insulation.

The sheath protects the thermocouple from contamination and chemical attack. It also provides mechanical stability. This allows the thermocouple “assembly” to be formed, bent and shaped in many ways. Flanges, fittings, etc. can also be mounted on to the sheath. These options allow metal-sheathed thermocouples to be mounted into a variety of applications.

Junction Types

When thermocouples are assembled into metal - sheathed thermocouples, there are 3 ways we can orient the thermocouple junction in the assembly. They are grounded, ungrounded and exposed.

Grounded

When assembling the thermocouple into a protective metal sheath, we can weld the thermocouple junction directly to the inside tip of the sheath (Figure 16). Why attach the junction to the sheath? Can you think of any reasons?

Attaching the junction to the sheath ensures rapid heat transfer from the sheath to the junction. Thus, the sheath protects the thermocouple junction while minimizing any heat transfer delays to it.

Figure 16
Grounded Junction



Figure 17
Ungrounded Junction



Figure 18
Exposed Junction



Ungrounded

The ungrounded junction is similar to the grounded junction, except it is isolated (insulated) from the metal sheath (Figure 17). Why insulate the junction from the metal sheath?

Insulating the thermocouple junction electrically isolates it from the sheath metal. This is done to prevent stray voltages on a machine from inducing a measuring error in the thermocouple. Ungrounded junctions are also more shock resistant and better survive under rapid temperature change conditions.

Unfortunately, the insulation slows down heat transfer to the thermocouple junction. An ungrounded junction in a MgO insulated, metal-sheathed thermocouple requires 2 to 3 times as long to respond to temperature changes as a grounded thermocouple.

Exposed

This type of junction protrudes from the end of the sheath, but is insulated from it (Figure 18). Because the junction is directly exposed to the material being heated, the junction responds very quickly to temperature changes. There is no sheath or insulation to slow down heat transfer.

The disadvantage, though, is that an exposed junction is not protected from mechanical damage and chemical attack. If the junction is damaged or chemically attacked, a measuring error will result.

Temperature Sensors

Thermocouple Review Questions

You've done well so far! Since practice makes perfect, take some time to work through the following review questions. After writing down the answers, go to page 33 and check to see how you did. If you miss any answers, go back into the text and restudy those sections.

1. A controller knows when the sensor is sending "bad" information. True or false.
2. Explain what a thermocouple is and how it functions.
3. A Type K thermocouple has a hot junction temperature of 500°F. Cold junction temperature equals 500°F. What is the millivolt output?
4. Explain how a controller uses "compensation" to provide the correct temperature reading when a thermocouple is used.
5. Thermocouples convert thermal energy into electrical energy. True or false.
6. What are the metal alloys used in a Type K thermocouple?
7. Thermocouple types are interchangeable. True or false.
8. One leg of a thermocouple is magnetic. One leg has red insulation. Which thermocouple type is this? Are you sure? Please explain.
9. Use grounded thermocouples in electrically noisy environments. That way the thermocouple wire can drain the noise to ground. True or false.
10. Name two advantages of ungrounded thermocouples versus grounded thermocouple junctions.
11. Why is correctly connecting the + and - legs to a controller important?
12. An accuracy of $\pm 1.2^{\circ}\text{C}$ ($\pm 2.16^{\circ}\text{F}$) is required at 500°F (260°C). Which thermocouple(s) will work in this application?
13. A customer wants to know the life of Watlow Gordon thermocouples. What is your response to the customer? Briefly explain.

**Resistance
Temperature
Detector (RTD)**

RTDs are precision temperature sensors. They are used in industrial applications as well as laboratories. RTD elements are typically more accurate than thermocouple elements and maintain that accuracy over a longer period of time. They are generally used up to 1200°F (650°C). How does an RTD work? How does it compare to a thermocouple? Let’s pursue the answers to these questions and many more!

A RTD can take many forms. The most often used RTD elements are shown below. Figure 19a shows a fine platinum element wire coiled around a very small diameter ceramic cylinder. Platinum resistance elements are most often used, but nickel, copper and nickel-iron are also used. Small lead wires are welded on to the resistance element. The assembly is then encapsulated in glass to seal it and prevent contamination.

Figure 19
Various RTD Element Styles

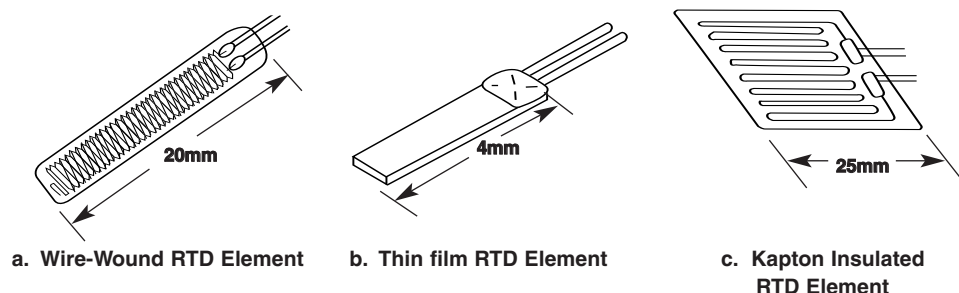

A RTD is also known as a “PT-100” or “PT 1000”, depending on the RTD’s base resistance.

The RTD in Figure 19b is formed by depositing a thin film of platinum or other metal on to a ceramic substrate (platelet). Leads are again attached and the substrate coated with glass or epoxy for protection. Figure 19c shows a platinum wire laid out between two layers of Kapton* material. This design has the advantage of being flexible.

How do RTDs work? A RTD is a sensor whose **resistance** changes fairly linearly as temperature changes. A controller measures this resistance value and converts it into a temperature reading. Unlike a thermocouple, there is no electrical signal generated by a RTD. So a controller must measure the resistance by passing a small current through the RTD. Based on the current and voltage used, it calculates the resistance (remember $V = IR$ from Book 3?).

A RTD’s resistance value *increases* as temperature increases (and decreases as temperature decreases). As Figure 20 shows, the resistance versus temperature curve is very linear. This curve is also known as a “TCR” or “temperature coefficient of resistance” curve.

Figure 20
RTD Resistance Vs Temperature (TCR) Curve

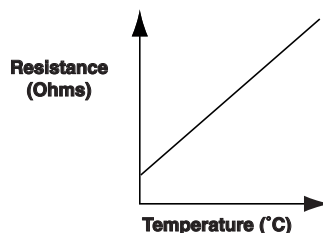

Temperature Sensors

RTD Standards

A RTD uses a “base” resistance value. For example, most platinum RTDs have a base value of 100 ohms at 0°C (32°F). Some platinum RTDs, however, have a base resistance of 500 or even 1000 ohms at 0°C. Other metals use other base resistance values (Figure 21). Regardless of the base value, all RTDs follow a very linear resistance versus temperature relationship.

Figure 21
Base Resistance Values of Various RTD Elements

Element Type	Temperature Range	Base Resistance	TCR($\Omega/\Omega/^\circ\text{C}$)
Platinum DIN	-200 to 650°C (-330 to 1200°F)	100 Ω at 0°C	0.00385
Platinum JIS	-200 to 650°C (-330 to 1200°F)	100 Ω at 0°C	0.003916
Copper	-100 to 260°C (-150 to 500°F)	10 Ω at 25°C	0.00427
Nickel	-100 to 205°C (-150 to 400°F)	120 Ω at 0°C	0.00672

We will focus on *platinum element RTDs* since they are used in almost every industry. There are two industrial standards for platinum RTDs: the DIN and JIS standards. **DIN** uses a resistance vs. temperature curve (TCR) of 0.003850 ohms/ohm/°C. **JIS** uses a resistance vs. temperature curve (TCR) of 0.003916 ohms/ohm/°C.

The Watlow Gordon catalog’s Application Guide has tables which list the resistance versus temperature values for both of these standards. Turn to those now. The DIN table is partially reprinted below. Then do Exercise Four.

Figure 22
DIN Standard RTD Resistance Vs Temperature Values for a 100 Ohm RTD

°C	0	1	2	3	4	5	6	7	8	9
0	100.00	100.39	100.78	101.17	101.56	101.95	102.34	102.73	103.12	103.51
10	103.90	104.29	104.68	105.07	105.46	105.85	106.24	106.63	107.02	107.40
20	107.79	108.18	108.57	108.96	109.35	109.73	110.12	110.51	110.90	111.28
30	111.67	112.06	112.45	112.83	113.22	113.61	113.99	114.38	114.77	115.15
40	115.54	115.93	116.31	116.70	117.08	117.47	117.85	118.24	118.62	119.01
50	119.40	119.78	120.16	120.55	120.93	121.32	121.70	122.09	122.47	122.86
60	123.24	123.62	124.01	124.39	124.77	125.16	125.54	125.92	126.31	126.69
70	127.07	127.45	127.84	128.22	128.60	128.98	129.37	129.75	130.13	130.51
80	130.89	131.27	131.66	132.04	132.42	132.80	133.18	133.56	133.94	134.32
90	134.70	135.08	135.46	135.84	136.22	136.60	136.98	137.36	137.74	138.12

Exercise Four

Use the RTD Resistance Vs Temperature tables in the Watlow Gordon catalog to fill in the resistance values. Answers on p. 33.

DIN RTD: 0°C: _____ ohms 20°C: _____ ohms 240°C: _____ ohms

JIS RTD: 0°C: _____ ohms 20°C: _____ ohms 240°C: _____ ohms

RTDs Standards (con't)

What did you discover? First, the resistance values are **equal** at 0°C. Second, as the temperature increases, the difference between the DIN and JIS values also increases. Why? The DIN and JIS resistance vs temperature (TCR) curves are different! So, we expect the resistance values to be different at any given temperature (except 0°C of course).

Will a controller which is set up to use a DIN RTD measure temperature accurately if a JIS RTD is used instead? No. As temperature increases a larger and larger resistance (and thus measuring) error results. So, do not use JIS RTDs in DIN RTD input temperature instruments and vice versa.

RTD Advantages/ Disadvantages

If we have thermocouples, why bother with RTD sensors? RTD sensors have several big advantages over thermocouples. The major advantages are stability, repeatability and accuracy. They also have a few disadvantages like cost and temperature range and response to temperature changes. These are summarized in Figure 38 on page 31. Let's start with the disadvantages first.

Cost

As we know, platinum is expensive. Expensive materials and more complex manufacturing techniques are required to make RTDs. Thus, RTD sensor elements cost many times what a simple thermocouple does. When built into assemblies, however, the cost ratio drops to about 2 times or more than a comparable thermocouple assembly.

Temperature Range

Platinum RTDs are used in the -200° to 650°C temperature range. There are also RTDs which are rated to 850°C (1560°F) for certain applications. The limitation of the other RTD element materials (nickel, etc.) is that their useful operating temperature range is much less than platinum's (refer back to Figure 21).

Response Time

A thermocouple junction is very small and easily heated. It quickly reaches part temperature and measures accurately. An RTD element doesn't have it so easy! If you look at the RTDs shown in Figure 19, only the thin film RTD comes close to matching the small size of a thermocouple junction.

RTD elements respond much slower to temperature changes for two reasons. One, heat has to transfer through the epoxy or glass coatings of the resistance element metal. Two, the *entire* RTD element must reach a uniform temperature before it measures an accurate temperature. If the temperature is not the same throughout the RTD element, it will measure an incorrect temperature. As a rule, RTD metal-sheathed assemblies respond 2 to 4 times slower to temperature changes than comparable thermocouple assemblies.

Temperature Sensors

RTD Advantages/ Disadvantages

The main advantages of the RTD are its stability, repeatability and high accuracy.

Stability and Repeatability

RTDs are very stable over time. That is, they do not “drift” like thermocouples do. This means that RTD measurements are much more accurate over a given period of time. In other words, if it measures 100°C today, it will measure 100°C tomorrow, the next month and so on.

Repeatability refers to the RTD’s ability to accurately measure the same temperature after repeated heating and cooling cycles. Temperature cycling tends to make thermocouples “wobble” within their tolerance bands. For example, if a RTD is placed in a 100°C oven and it measures 100.0°C, then it will still measure 100.0°C (or close to it) even after you heat up and cool down the sensor many times. A thermocouple, in contrast, measures 100°C once, then maybe 99, then 101, then 100°C and so on. So the RTD is more precise over many temperature measurements.

Life and Accuracy

Since we are on the subject of accuracy, let’s compare the RTD’s accuracy with that of several thermocouples. An excerpt of the Initial Calibration Tolerances table of DIN and JIS platinum RTDs is shown in Figure 9, back on page 10.

To calculate the initial accuracy of a RTD, you simply look up the tolerance value for a given temperature. The “A” and “B” stand for “class A” and “class B,” respectively. This is similar to thermocouples which use “special” and “standard” tolerances.

Example: A DIN platinum RTD is heated to 500°F (260°C). What are the class A and B tolerances at this temperature? From Figure 9, the class A tolerance is $\pm 1.21^\circ\text{C}$. The class B tolerance is $\pm 2.88^\circ\text{C}$. Compare this to thermocouple tolerances at the same temperature! Only the platinum-based type R and S thermocouples are close. In fact, their tolerances are just slightly better. The RTD, however, will cost many times less than the type R or S thermocouple.

Exercise Five

A customer requires an accuracy of $\pm 3^\circ\text{F}$ at an operating temperature of 950°F (510°C). It is important that the accuracy and stability be maintained over a long time. Will a RTD work in this application? Answer on page 33.

Why are the tolerances called “initial” calibration tolerances and not just calibration tolerances? The same thing applies here as did for thermocouples. After their initial use, some slight physical and chemical changes take place in the platinum wire. These changes alter the resistance characteristics and can cause the RTD element to go outside of its initial accuracy range.

RTD Lead Wire Effects

Let's test a DIN standard RTD at room temperature (20°C or 68°F). From Exercise Four, we anticipate that a DIN standard RTD will have a resistance of 107.79 ohms at 20°C (68°F). To prove this, let's connect an RTD assembly up to an ohmmeter and measure the resistance (Figure 23). Of course, we make 100% sure that the entire RTD is at 68°F. What do you think we will measure?

Figure 23

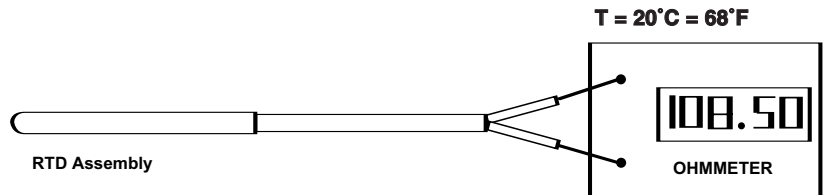

The ohmmeter display shows 108.5 ohms!! What's wrong? The display should read 107.79 ohms according to the table we used. What happened?

You see, an ohmmeter (or a temperature control) measures the resistance of the entire RTD circuit! In our test, the ohmmeter measured the RTD element resistance **and the lead wire resistance**. THAT is why we measured a higher resistance than the table showed! This is known as the RTD "lead wire effect."

Do you think this added resistance causes a problem? Sure it does. The added resistance tricks a controller into believing that the sensor temperature is higher than it really is. Any lead wire resistance will be a source of error. Therefore, we will not have accurate temperature measurement. How can we eliminate this problem?

One thing we can do is measure or calculate how much resistance is in the lead wires. Then, we adjust the instrument or controller to compensate for the lead wire resistance error. This sounds a bit difficult doesn't it? Is there a better way? There is! We can attach one additional lead wire to one end of the RTD element. In Figure 24a, you see how this "3-wire" RTD looks.

What does a third lead wire do? Electronic circuitry in the controller measures the resistance through wires 2 and 3. This is then subtracted from the total circuit resistance through wires 1 and 2. Now the control knows the true resistance value of the RTD!

Figure 24
3-Wire RTD and 4-Wire RTD

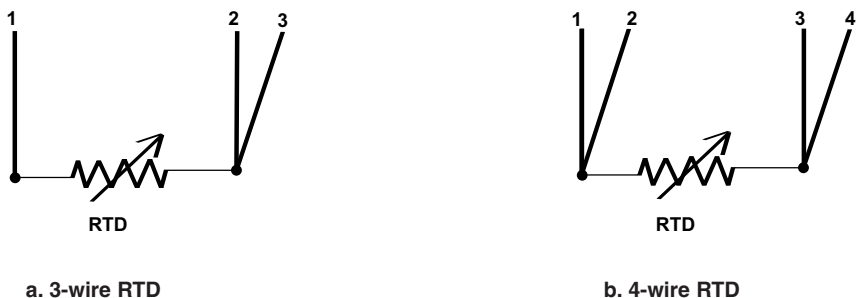

Temperature Sensors

RTD Lead Wire Effects (con't)

3-Wire RTDs are the most popular ones used in industry.

A 4-wire RTD is sometimes used for very long lead lengths or for better accuracy (Figure 24b). It uses the same principal as used in 3-wire RTDs. In 4-wire RTDs, the controller measures the resistance of each lead wire "loop." It then subtracts out the resistance of each loop to read the true RTD resistance value.

Another method of lead wire compensation is to connect a 2 or 3-wire RTD to a transmitter. A transmitter converts the RTD resistance reading into a low amperage signal. This is then transmitted to the temperature controller.

RTD Identification

Identifying a RTD is easy. A 2-wire RTD typically uses the **same** color lead wire for both leads. A thermocouple uses **different** color leads for each leg. Also, if you measure the resistance between the 2 wires (at room temperature), a RTD's resistance will be somewhere between 107 and 110 ohms. A thermocouple will have a very low resistance - perhaps a few ohms maximum.

Per DIN-IEC-751 and ASTM E1137 standards, a 3-wire DIN RTD has 2 red leads and one white lead (for the compensation wire). A 4-wire DIN RTD has 2 red leads and 2 white leads. How do you know which white lead goes with which red lead? If they are not labeled, measure the resistance values between leads. Compare your results to Figure 25 below to identify the correct leads. Watlow Gordon follows this color code practice for JIS RTDs as well.

Figure 25
Resistance Measurements in a 4-Wire RTD Assembly

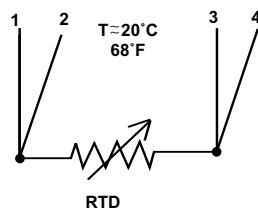

Lead- to-Lead Measurement	Distance at Room Temperature
1 to 2; 3 to 4	Less than 1 ohm to a few ohms maximum
1 to 3; 1 to 4 2 to 3; 2 to 4	≈ 107 to 110 ohms

Exercise Six

A customer calls and says that he would like a sensor replacement, but doesn't know what kind of sensor it is. It is either a 4-wire RTD or a two (dual) thermocouple sensor! Two wires are blue and two wires are red. Explain how you will determine if this is a RTD or thermocouple. Answer on page 33.

RTD Assemblies

Now that you know how a RTD works and what some considerations are in applying it, let's take a brief look at RTD assemblies you can expect to see in industry. A Kapton insulated RTD (Figure 19c) is used as is. Wire wound and thin film RTDs (Figures 19a and 19b) are often assembled into metal sheaths.

In lower temperature versions (up to 500°F or 260°C), the RTD element is welded or otherwise attached to copper or nickel lead wires. This sub-assembly is placed in a closed-end tube. A powder, cement or thermal grease is used to fill the tube. An epoxy seal seals out moisture and anchors the RTD element and leads in the tube (Figure 26a).

In higher temperature versions (up to 1200°F or 650°C), the RTD is fitted into a cavity dug into the end of a piece of mineral insulated (MgO) metal-sheathed cable. The wires buried in the cable are welded to the RTD element. A cap is filled with MgO and placed over the element end and mounted (Figure 26b).

Figure 26

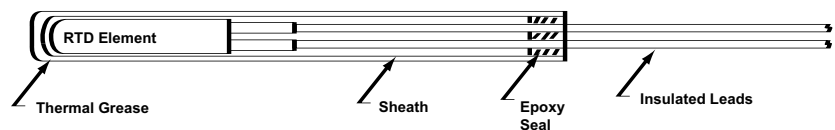

a. Low Temperature RTD Assembly

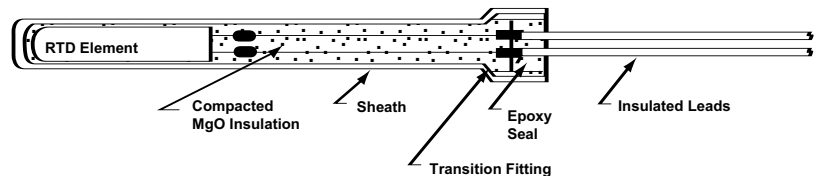

b. High Temperature (Mineral Insulated) RTD Assembly

RTD Review Questions

Now is your chance to put your new knowledge to use. Answer the following questions below. After writing down the answers, go to page 34 and check your work. If you miss any answers, restudy those sections in the text.

1. Explain what a RTD is and how it functions.

2. The RTD's resistance increases with temperature increase. True or false.

3. RTDs have a temperature range that is about the same as thermocouples. True or false.

4. Briefly explain what JIS and DIN RTD standards are.

Temperature Sensors

RTD Review Questions (con't)

5. Name 2 things we can do to compensate for the additional resistance of RTD lead wires.
6. Using the Watlow Gordon Application Guide, find the approximate accuracy of a class B JIS RTD at 410°F (210°C). Is this better than a Type T thermocouple at 410°F?
7. Name the 3 main reasons why RTDs are chosen over thermocouples.
8. Fortunately, DIN and JIS standard are interchangeable. True or false.
9. RTD elements respond twice as fast as thermocouple junctions to temperature changes. True or false.

Thermistor

The thermistor is a semiconductor used as a temperature sensor. It is manufactured from a mixture of metal oxides pressed into a bead, wafer or other shape. The bead is heated under pressure at high temperatures and then encapsulated with epoxy or glass (Figure 27). Beads can be very small, less than 1 mm in some cases.

The result is a temperature sensing device that displays a very distinct non-linear resistance versus temperature relationship (Figure 28). The resistance decreases as temperature increases. This is called a negative temperature coefficient (NTC) thermistor.

Figure 27

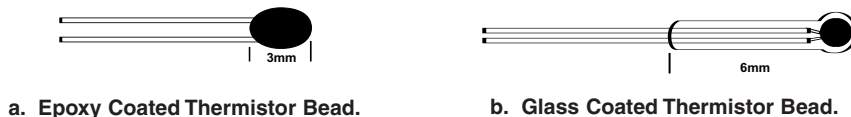
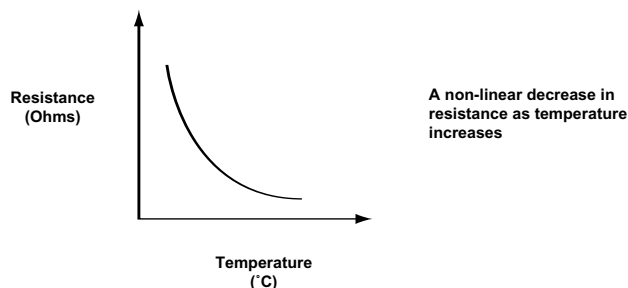

Figure 28

Thermistor Resistance Vs Temperature Relationship (NTC)



Thermistor (con't)

A thermistor's sensitivity to temperature changes and small size make it ideal for use in medical equipment.

Thermistors exhibit a very large resistance change for a small temperature change. This can be as large as 3 to 5% per °C (versus 0.4% per °C for RTDs). This makes them very sensitive to small temperature changes. They can detect temperature changes as low as 0.1°C or smaller. A thermistor element is significantly smaller in size compared to RTD's, yet are often built into the same type of protective assemblies. Typical ranges of use are -100°C to 300°C (-120°F to 570°F).

Thermistor Standards

There are presently no industrial or worldwide standards for thermistors (as with the RTD). The base resistance of thermistors vary anywhere from 1000 to one million ohms! The resistance vs. temperature curves (TCRs) vary a lot as well. Each manufacturer and country uses different standards. Therefore, you must be careful not to use the wrong thermistor type.

Base resistance values are typically measured at 25°C or 77°F (instead of 0°C for RTDs). The Application Guide of the Watlow Gordon catalog has tables showing the base resistances and TCRs for a variety of thermistors.

Exercise Seven

Use the Thermistor TCR tables to find the resistance values at the following temperatures for the Watlow Gordon No. 11 - 1000 ohm thermistor. Answers on page 33.

-68°C: _____ ohms 25°C: _____ ohms 120°C: _____ ohms

Using the wrong thermistor with your controller will cause very large errors in temperature values! Compare the resistance values of the Watlow Gordon No. 10 and the No. 16 thermistors at 10°C. The No. 10 thermistor has 519.1 ohms while the no. 16 thermistor has 208,000 ohms! The temperature controller will not control properly if the wrong thermistor is used.

The thermistor is limited to a small temperature range in which it maintains its accuracy. The number of applications for which the thermistor can effectively be used are limited. Presently, most are seen in medical equipment markets. Another area where thermistors are used are for engine coolant, oil, and air temperature measurement in the transportation industry.

Thermistor Lead Wire Effects

Lead wire used for the thermistor adds to the overall resistance of the thermistor (as with the RTD). However, the base resistance of the thermistor is so large (1000 ohms or more), that the added lead wire resistance has very little to no effect on the temperature reading. Thus, no resistance compensation is required for thermistors.

Temperature Sensors

Thermistor Assemblies

Thermistor bead elements are often not assembled into a metal sheath. The elements are used bare in the application. If a thermistor is built into a metal-sheathed assembly, it is done in the same manner as for RTDs (Figure 26).

Infrared Sensor

Thus far, we have explored contact temperature sensors. That is, the sensor must *physically touch* a material before it can sense that material's temperature. What happens if this physical contact is not possible? Our only alternative is to use a non-contact sensor.

As the name implies, non-contact sensors measure an object's temperature without actually touching it. The non-contact sensors we focus on are called infrared sensors. Most Infrared or IR sensors (including Watlow's) can sense temperatures up to about 1000°F (540°C). Above these temperatures other non-contact sensors are used (like pyrometers). Let's begin by first exploring how an IR sensor works.

Infrared Sensor Function

From the Heat Transfer book, you know that all hot objects radiate and absorb electromagnetic waves. For example, sunshine striking your face feels "hot," because your face absorbs the sun's radiant energy (Figure 29).

Figure 29

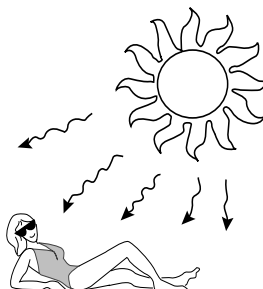

An object also radiates energy across many *wavelengths*. These particular wavelengths are called "infrared radiation" or "infrared waves." An infrared sensor intercepts a portion of the infrared energy radiated by an object (Figure 30). The radiation it intercepts is typically in the 8 - 14 micron wavelength range. The infrared waves are focused through a lens (or optical system) on to an infrared detector. The detector absorbs the radiation striking it and converts this into an electric output signal.

Figure 30

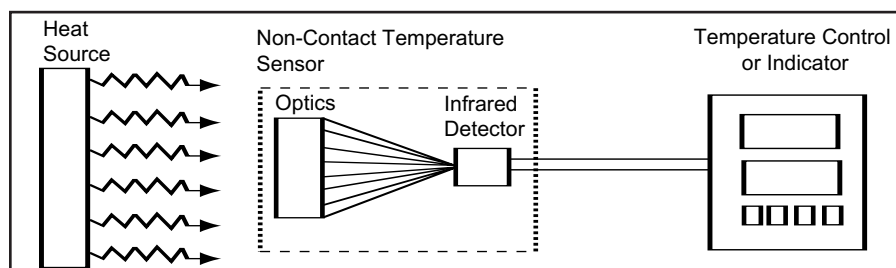

Infrared Sensor Function (con't)

The electronics which amplify and condition the detector's output signal are located either in the sensor, in a "pod" in the connection cable or in the temperature controller.

The electric output signal is proportional to the amount of radiation striking it. So, as more infrared energy strikes the detector, more electrical energy is produced. This output signal is then amplified and conditioned by support electronics (and/or temperature controller) and converted into a temperature value.

That's about it! The tricky part though is applying the IR sensor to obtain accurate temperature measurement! The following sections explore some of the basics in IR sensor application.

Emissivity Effects

Remember what emissivity is? It is the ability of a material to radiate or absorb electromagnetic waves. When using radiant heaters, should the target have a high or low emissivity? A high emissivity! A high emissivity means that the target object will absorb most of the radiation striking it. Does the same thing apply when we measure object temperatures with infrared sensors? What do you think?

Yes! As a general rule, the **higher the target emissivity, the better**. Why will high emissivities work better than lower emissivities? Good question! Let's find out by using a simple example.

Some IR sensors can be tuned for specific emissivity values. Some IR control systems have emissivity and reflectivity adjustments as well.

Example: In Figure 31, IR sensor A is set up to measure objects with $e = 0.9$. IR sensor B is set up to measure objects with $e = 0.5$. If object emissivity varies by 0.05, how much measuring error will each sensor have?

Figure 31

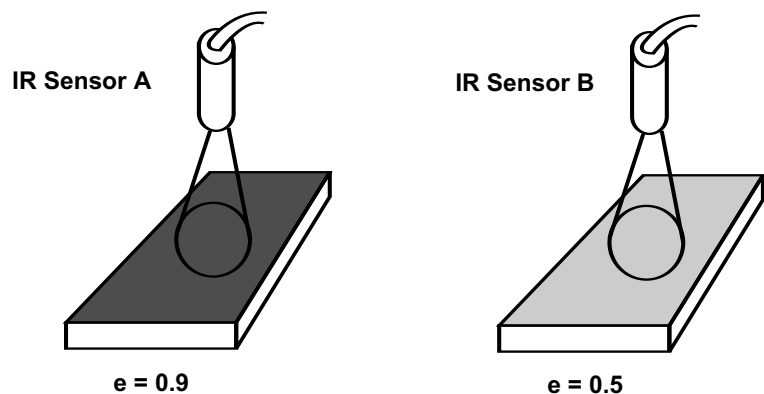

As a percentage, IR sensor A has only a 5½% ($0.05/0.9$) measuring error. IR sensor B has a 10% ($0.05/0.5$) measuring error. See how much greater the error is when measuring lower emissivity objects with sensor B? To reduce measuring errors we want to measure objects with the highest emissivity possible! In practice, IR sensors are rarely used for materials with less than $e = 0.5$ or 0.6 .

Temperature Sensors

Sensor-to-Target Distance

As shown in Figure 32, an infrared sensor has a cone-shaped “field of view.” All infrared radiation in this field of view will be detected by the sensor.

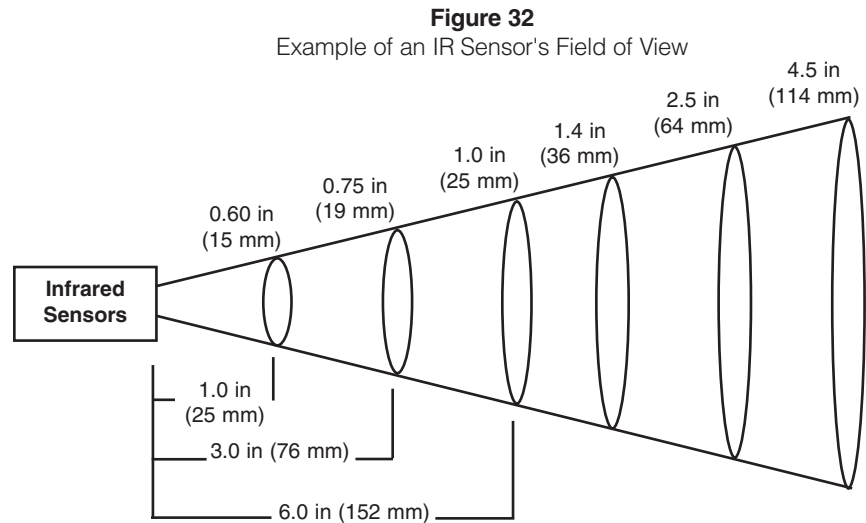

Unfortunately, the sensor cannot filter out any “bad” radiation it happens to “see.” In Figure 33, position 1, the IR sensor can “see” both the target object and background objects. Therefore, it will measure some average temperature between these two targets. If this happens, the controller will be tricked into maintaining the wrong work load (target) temperature!

How do we correct this problem? We simply move the target and IR sensor closer together (Figure 33, position 2). This prevents the IR sensor from “seeing” any other objects. The IR sensor can now measure true target temperature.

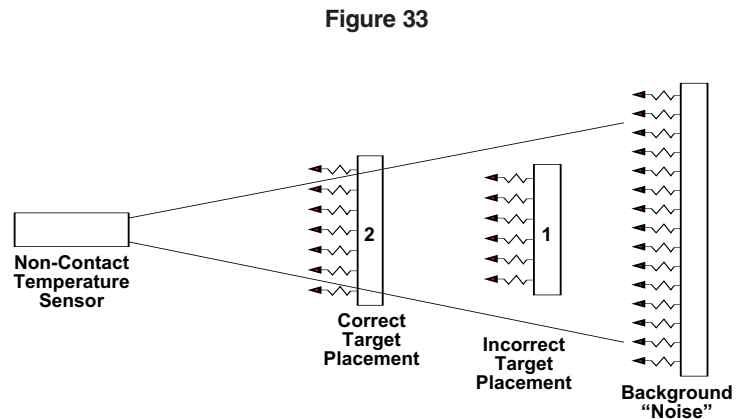

The spot size (shown in Figure 31) is the circular area which the IR Sensor can “See” on the Target.

As a rule, *the target size should be at least 1.5 to 2 times the “spot size”*. The “spot size” is the diameter of the circular view that the IR sensor has of the object. For example, if an object measures 8 by 4.5 inches wide (200 x 115 mm), the maximum spot size should be 3 inches (75 mm) in diameter.

Background radiation can also enter an IR sensor when it is used to measure thin-film plastics (Figure 34). These materials are very transmissive. That is, the sensor “looks” through the thin material and senses the temperature of objects behind the film. IR sensors should not be used in these types of applications.

Sensor-to-Target Distance
(con't)

Background radiation can also enter an IR sensor's lens by reflecting off of the target (Figure 35). This reflected radiant energy will alter the IR sensor's temperature measurement and cause errors.

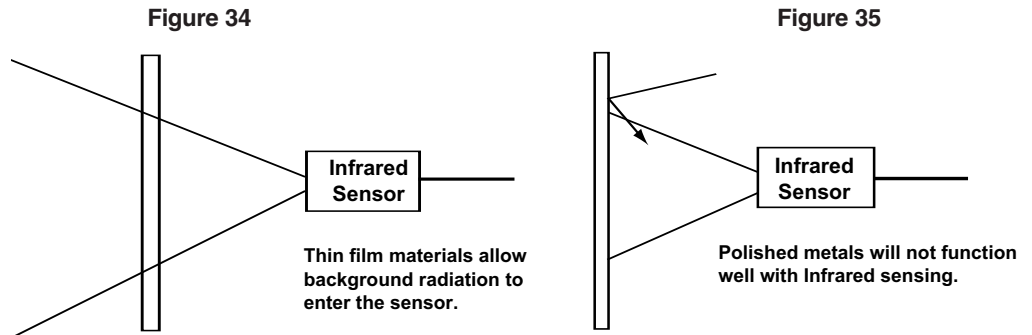

To reduce this problem, an IR sensor should always be set at a right angle with respect to the target (Figure 36). However, if space limitations exist, the IR sensor can be mounted up to a maximum of 45° (per Figure 36).

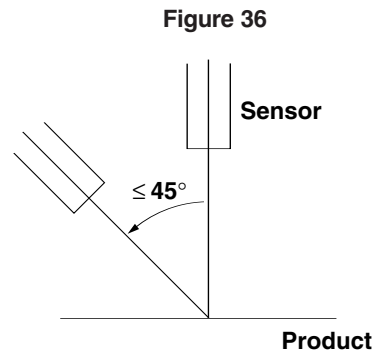

Operating Environment

Smoke, dust, and fog block your eye's ability to see objects. Infrared sensors have the same problem! Smoke, dust, and vapors from manufacturing processes absorb or reflect infrared radiation before it gets to the sensor lens (Figure 37). Why is this a problem?

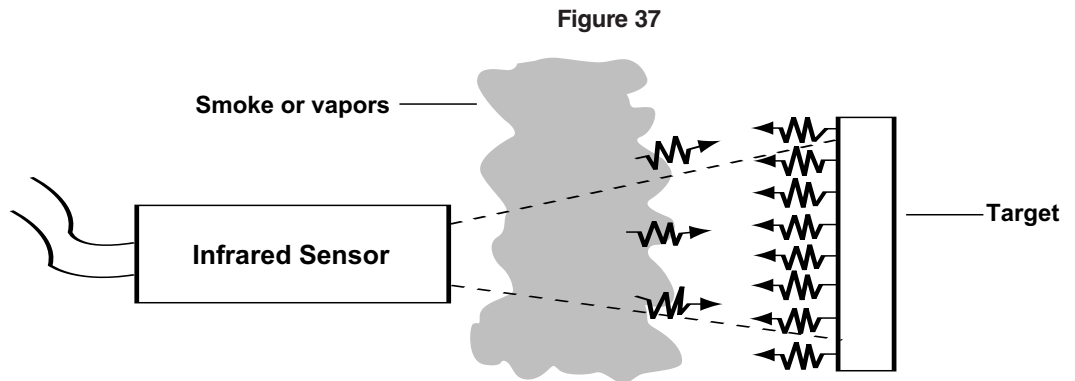

The IR sensor only can measure what it "sees." If it "sees" smoke and dust (as well as the target object), it measures some average of the target, smoke and dust temperatures. This, of course, causes the controller to maintain the target (work load) at the wrong temperature! Therefore, it is important to have a clean environment for infrared sensors to "look through".

Temperature Sensors

Ambient Temperature Fluctuations

The Watlow infrared sensors can typically measure temperatures up to 1000°F (540°C). The sensor itself, however, cannot survive at those temperatures. It can only operate in maximum air temperatures up to about 50 to 65°C (depending on type of IR sensor used). Therefore, we must ensure that the sensor is operating cool enough to measure accurately.

What happens though if the ambient air temperature changes? This causes the IR sensor to get hotter or colder as well. Is this a problem? It does cause temporary problems. Temperature changes in the infrared detector induce measuring errors. As soon as the IR sensor temperature stabilizes, however, it again measures accurately. Thus, many IR sensors are insulated to prevent or at least slow the affects of changing ambient temperatures.

Advantages/ Disadvantages Of The Four Sensor Types

To be honest, the majority of industrial applications call for thermocouples. Then why did we spend so much time on the other sensors?!? What do YOU think? Watlow customers *expect* you to know a lot about sensors. They *depend* on you to give them the best advice. How can you *possibly* do that if you only “know” about thermocouples? The answer is that you can’t. By having explored temperature sensing, you are a step ahead of many competitors.

To make life a bit easier, we have compiled the following comparison chart. You can use this comparison chart to give you a head start. Who knows? That head start may just win you a loyal customer!

Figure 38
Temperature Sensor Comparison Chart

Sensor	Advantages	Disadvantages
Thermocouple	<ul style="list-style-type: none"> • Simple, Rugged • High temperature operation • Low cost • No resistance lead wire problems • Point temperature sensing • Fastest response to temperature changes 	<ul style="list-style-type: none"> • Least stable, least repeatable • Low sensitivity to small temperature changes • Extension wire must be of the same thermocouple type • Wire may pick up radiated electrical noise if not shielded • Lowest accuracy
RTD	<ul style="list-style-type: none"> • Most stable over time • Most accurate • Most repeatable temperature measurement • Very resistant to contamination/ corrosion of the RTD element 	<ul style="list-style-type: none"> • High cost • Slowest response time • Low sensitivity to small temperature changes • Sensitive to vibration (strains the platinum element wire) • Decalibration if used beyond sensor’s temperature ratings • Somewhat fragile
Thermistor	<ul style="list-style-type: none"> • High sensitivity to small temperature changes • Temperature measurements become more stable with use • Copper or nickel extension wires can be used 	<ul style="list-style-type: none"> • Limited temperature range • Fragile • Some initial accuracy “drift” • Decalibration if used beyond the sensor’s temperature ratings • Lack of standards for replacement
Infrared	<ul style="list-style-type: none"> • No contact with the product required • Response times as fast or faster than thermocouples • No corrosion or oxidation to affect sensor accuracy • Good stability over time • High repeatability 	<ul style="list-style-type: none"> • High initial cost • More complex - support electronics required • Emissivity variations affect temperature measurement accuracy • Field of view and spot size may restrict sensor application • Measuring accuracy affected by dust, smoke, background radiation, etc.

Booklet Review Questions

You've come a long way on your journey of sensor discovery! Now, put into practice what you have learned by answering the following questions. Use the previous book sections, the Watlow Gordon catalog and the Sensor Comparison Chart on page 31 to help you. Answers are on pages 34 and 35.

1. What is a thermistor and how is it used to measure temperatures? Briefly explain.
2. Describe how an infrared sensor functions. Draw a diagram in the left margin to help you explain.
3. What is background radiation? Why is it a problem? Briefly explain.
4. A customer has 2 thermistors. Both have a base resistance of 1,000 ohms, but each have different resistance versus temperature curves (TCRs). Can one be replaced with the other? Explain your answer.
5. A part measures 4 by 5 inches (100 x 125 mm). What is the maximum recommended spot size for this "target?" Be specific.
6. Smoke and dust in front of an infrared sensor's lens does not affect its ability to accurately detect the target temperature. True or false.
7. A customer wants to measure temperature in a 100°F (55°C) band and accurately measure very small temperature changes. Which sensor do you recommend? Why?
8. A customer wants to measure the temperature of a metal plate, but can't decide whether to use a thermocouple or IR sensor. The plate has an emissivity of 0.7. Quick temperature response and long life are required. Do you recommend using an IR sensor or mounting a thermocouple in the plate? Please choose a sensor type and defend your choice.

Temperature Sensors

Booklet Review Questions (con't)

9. What happens to the infrared sensor when the ambient temperature changes rapidly? Is this an irreversible condition or will it self-correct?
10. One leg of a thermocouple has blue insulation. None of the legs is magnetic. One of the legs looks like a copper wire. What thermocouple type is this? Use Figures 7, 11 and 12 to help you.
11. A customer wants to use a ceramic-beaded style thermocouple to sense oven temperatures up to 1000°C. A “pretty good” accuracy is required. Do you recommend a Type J or K thermocouple? Briefly explain your answer.
12. A customer requires an accuracy of $\pm 1.5^\circ\text{C}$ ($\pm 2.7^\circ\text{F}$). The operating temperature is 482°F (250°C). Determine which thermocouple types and RTD classes can meet this accuracy requirement.
13. Name 1 advantage and 1 disadvantage when switching from a grounded to an ungrounded thermocouple.
14. A customer wants a very accurate temperature sensor for her application. The sensor’s accuracy and ability to measure accurately over long periods of time is important. Which sensor do you recommend and why?

Answers to Exercises and Review Questions**Answers to Exercises**

1. $0^{\circ}\text{C} = 0\text{ mV}$; $20^{\circ}\text{C} = 1.019\text{ mV}$; $200^{\circ}\text{C} = 10.779\text{ mV}$; $560^{\circ}\text{C} = 30.788\text{ mV}$ per ITS - 68 standards. ITS-90 standards may vary.
2. Type J = 8.562 mV; K = 6.54 mV; T = 7.209 mV
3. Types E, J, K and N will work with special tolerances ($500^{\circ}\text{C} \times \pm 0.004 = \pm 2^{\circ}\text{C}$). Type T will not work, because its maximum temperature is 350°C .
4. DIN - 100, 107.79 and 190.45 ohms, respectively per ITS-68 standards; JIS - 100, 107.93, 192 ohms, respectively per ITS-68 standards.
5. Yes, at 950°F a class A DIN or JIS RTD will work.
6. Starting with the blue (or red) lead, measure the resistances values between it and the other 3 leads. If two of these values is around 107 to 109 ohms, you know that you have a 4 wire RTD. If the resistance value between a blue and red lead is a few ohms and very high ohms between leads of the same color, you have a dual thermocouple.
7. -68°C : 101,343 ohms 25°C : 1000 ohms 120°C : 64.7 ohms

Answers to Thermocouple Review Questions

1. False.
2. A thermocouple is made of two different metal wires connected at a junction. A temperature difference between the measuring junction and reference junction sets up a millivolt signal. This signal increases as temperature increases and thus can be used to measure temperature.
3. 0 mV, because both hot and cold junctions are at the same temperature.
4. A controller "compensates" by adding a room temperature millivolt signal to the incoming thermocouple signal. This then provides the correct temperature value on the display.
5. True.
6. Positive leg (KP) is Ni - 90%, Cr - 10%; Negative leg (KN) is Ni - 95%, 5% various elements.
7. False.
8. This can be either a Type J or Type K. To further identify it, you can find out the insulation color of the other leg. Then determine which color is the magnetic one. You could also check control terminals to see which is plus and which is minus. You could possibly measure wire resistivity and compare.
9. False.

Temperature Sensors

Answers to Exercises and Review Questions (con't)

10. Advantages are: Eliminate electrical interference and better withstand heavy temperature cycling.
11. If + and - legs are reversed, measured temperature will go in opposite direction of actual temperature, causing control problems.
12. All special tolerance thermocouple types can be used.
13. Life depends on many factors. What time period of Life do you mean? To give us an idea of how long a thermocouple will measure accurately, we have to determine your accuracy requirements, what the operating conditions are, what size thermocouple you require, etc.

Answers to RTD Review Questions

1. A RTD use resistance to measure temperature. As temperature increases so does the resistance. The RTD is typically made of a platinum wire resistance element.
2. True.
3. False.
4. These standards state the TCR (or temperature coefficient of resistance) for the RTD element. The JIS RTD has a 0.003916 ohm/ohm°C resistance change compared to DIN's 0.00385 ohm/ohm/°C change.
5. Compensate for lead resistance by adjusting the temperature display on the controller, use 3 or 4-wire RTDs, or use a transmitter.
6. Approximately $\pm 2.4^{\circ}\text{F}$. (Exactly through interpolation $\pm 2.43^{\circ}\text{F}$)
7. Any two of these - accuracy, stability, repeatability, area sensing, resistant to contamination.
8. False.
9. False.

*Answers to Exercises and
Review Questions (con't)*

Answers to Booklet Review Questions

1. A thermistor is a semiconductor device using resistance to measure temperature. It is very sensitive to temperature changes, but can only be used for narrow temperature ranges.
2. An infrared sensor intercepts a portion of the IR radiation emitted by an object. The radiation is focused through a lens on to an infrared detector which generates an electrical signal based on the object's temperature. The signal is amplified and conditioned so it can be read as a temperature by the controller.
3. It is radiation from other objects which the IR sensor can "see". These objects are either directly in the sensor's field of view or is radiation reflected by the target surface. This causes inaccurate temperature measurement of the target object.
4. The two thermistors cannot be interchanged, because if each has a different TCR, than they will have very different resistance readings at any given temperature. This will trick the controller into controlling at the wrong temperature.
5. The part size should be 1.5 to 2 times the spot size. Thus, the maximum spot size should be 2 to 2.7 inches ($4/2 = 2$; $4/1.5 = 2.7$).
6. False. Smoke prevents the IR sensor from "seeing" the target. Thus an inaccurate temperature measurement results.
7. The thermistor is recommended, because accurate temperature changes are required over a narrow temperature band.
8. Actually, based on the information given, either sensor will work. If you chose an IR sensor, the $e = 0.7$ is acceptable. Also the quick temperature response and long life are strong points for the IR sensor. A thermocouple also has quick response and can have a long life depending on what "life" means to the customer.
9. The sensor reading fluctuates and measures inaccurately for a period of time. After some time, the IR sensor temperature stabilizes and it again reads accurately.
10. Type T.
11. Recommend Type K as Type J cannot be used above 750°C . Accuracy for standard Type K wire at 1000°C is $\pm 7.5^{\circ}\text{C}$.
12. Class A JIS or DIN RTD can be used. Standard Type R or S and special Types E, J, K, N, T can be used.
13. Advantages: electrical isolation against stray voltages and better resistance to temperature cycling. Disadvantage: Much slower temperature response.
14. This describes an RTD's strong points! Choose a RTD.



Designer and Manufacturer of Industrial
Heaters, Sensors and Controls

Watlow St. Louis • 12001 Lackland Road • St. Louis, Missouri 63146 USA • Phone: 314-878-4600 • FAX: 314-434-1020

For information on other training books and materials available from
Watlow, please call 314-878-4600 or fax 314-434-1020

COR-WE4-0205